

TFR5

Room or outdoor temperature sensor



Description

CombiTemp™ TFR5 comprises a series of basic elements which can be combined in various ways to a CombiTemp TFR5 temperature sensor. The product offers great flexibility in respect to modification, service and maintenance.

The sensor can be made to feature a RTD output signal or with a built in FlexTop™ temperature transmitter types 2202, 2212, 2222 with 4-20 mA output (for documentation of FlexTops, please see relevant data sheet or operating instructions).

WARNING

For electrical installations and commissioning of the explosion protected devices, the data given in the conformity certificate as also the local regulations for installation of electrical apparatus within explosion protected areas must be considered. The intrinsically safe versions can be mounted in the explosion hazarded area according to its specification and only connected to a certified intrinsically safe supply loop with the corresponding electrical values.

After mounting of the device - do check that the housing has a ground potential.

The product contains non-replaceable parts, except from insert and/ or FlexTop transmitter if selected. In case of malfunction the product must be sent to Baumer for repair.

ATEX/IECEx data

Valid for TFR5 with FlexTop™ 2202 / 2212 / 2222

The FlexProgrammer 9701 configuration unit must not be connected to the FlexTop within the hazardous area.

Configuration procedure:

- Disconnect mains from the 4...20 mA loop circuit
- Disconnect the product from the circuitry within the hazardous area
- Bring the product to the safe area
- Connect the FlexProgrammer and perform the configuration

Field of application

CombiTemp™ TFR5 is a temperature sensor, based on RTD technology, which is designed for wall mounting or pipe mounting outdoor or indoor use, e.g. cold stores, freezing rooms or production facilities.

Safety instructions

This instrument is built and tested according to the current EU-directives and packed in technically safe conditions. In order to maintain this condition and to ensure safe operation, the user must follow the hints and warnings given in this instruction.

During the installation the valid national rules have to be observed. Ignoring the warnings may lead to severe personal injury or substantial damage of property.

The product must be operated by trained staff. Correct and safe operation of this equipment is dependent on proper transport, storage, installation and operation.

All electrical wirings must conform to local standards. In order to prevent stray electrical radiation, we recommend twisted and shielded input cables and also to keep power supply cables separated from the input cables. The connection must be made according to the connection diagrams.

Before switching on the power supply take care that other equipment is not affected. Ensure that the power voltage and the conditions is the environment comply with the specification of the device.

Before switching off the power supply voltage, check the possible effects on other equipment and the processing system.

Installation in accordance with UL approval

- Device is approved for indoor usage only.
- IP ratings are not evaluated by UL.
- Device must be supplied from external circuits of Class III and limited energy meeting requirements of cl. 9.4 of UL/CSA 61010-1 3rd ed. or Class 2 of UL1310.
- UL approved CYJV/7 or PVVA/7 cables with voltage, current and temperature ratings min. 90degC suitable for the application must be used.
- If the device is used in a manner not specified by the manufacturer, the protection provided by the equipment may be impaired.
- Maintenance free, no special requirements
- Cleaning method, no special requirements: with a soft, dry cloth

e. Reinstall the product in the hazardous area

f. Connect the power supply to the circuit

Valid for FlexTop™ 2222 only

Configuration for the FlexTop™ 2222 can be made within the hazardous area by means of a handheld HART configurator, providing the precautions and guidelines described in the product's manual are observed.

The TFR5 is also ATEX approved with transmitter for Ex ec for zone 2.

The TFR5 is approved without transmitter i.e. with Pt100 output only, as simple apparatus, Ex ia.

TFR5

Room or outdoor temperature sensor

Technical specifications

General specifications

Sensor stainless steel	AISI 316L
Housing	FlexHousing in Stainless steel, AISI 304
Mounting part	AISI 304
Electrical connection	Plug, M12, 5-wire or 8-wire
Cable gland	M16 M20
Cable diameter	M16 plastic 5 ... 10 mm M16 stainless steel 5 ... 9 - M20 plastic 8 ... 13 - M20 stainless steel 9 ... 13 -

 Be sure to fixate the instrument before tightening the cable gland.
 Tighten M16 glands or M20 plastic 2...2.5 Nm.
 Tighten M20 steel 2.5...3 Nm.

Ambient temperature (air temperature)	-50...160°C without transmitter / display -40...85°C with transmitter only -30...80°C with transmitter and display
Humidity	<98% RH, condensing
Protection class	IP67 / IP69K
Vibrations	GL, test 2

Sensor element specifications (DIN/EN/IEC 60751)

Sensor element	1 × Pt100
Accuracy (sensor element) (DIN/EN/IEC 60751)	Class B $\pm(0.3 + 0.005 \times t)^\circ\text{C}$ - 1/3 B $\pm 1/3 \times (0.3 + 0.005 \times t)^\circ\text{C}$ - 1/6 B $\pm 1/6 \times (0.3 + 0.005 \times t)^\circ\text{C}$ Class A $\pm(0.15 + 0.002 \times t)^\circ\text{C}$
Connection	Cable sensor 4-wire
Fixed sensor	2-wire
Cable	High-flexible silicone, grey
Cable temperature	-50...205°C
Protection class	Cable sensor IP 65
Response time, t_{50}	Air, 3 m/sec. 35 sec Air, no flow 135 sec.

Display

Type	Graphically LCD
Front glass	Polycarbonate
Display modes	8 modes, programmable e.g. value, bar graph, analogue
Background colour	White, green, red - programmable
Measuring range	-9999...99999
Digit height	Max. 22 mm
Accuracy	0,1% @ ambient -10...70 °C
Voltage drop	4V...6.5 V depending on backlight intensity
Output	2 configurable relay output 60 Vp, 75 mA
Programming	Touch screen or FlexProgrammer 9701

Further information can be found in separate data sheet and/or operation instructions for the Baumer graphical display, CombiView DFON.

Transmitter, type FlexTop 2202

Input	Pt100
Output	4...20 mA
Accuracy,	input <0.25°C @ ≤ 0...100°C output <0.1% signal span (16 mA)
Range	-200...850°C
Minimum span	25°C
Supply	8...35 VDC
Programmability	By FlexProgrammer 9701

Further information can be found in separate data sheet and/or operation instructions for FlexTop 2202

Transmitter, type FlexTop 2212 or 2222

Input	Pt100
Output	2212 4...20 mA 2222 4...20 mA / HART
Accuracy	input <0.06°C output <0.025% signal span (16 mA)
Range	-200...850°C
Minimum span	10°C
Voltage supply range	7 ... 40 V DC
Programmability	Both: Touch screen or FlexProgram 2222: By HART® modem

Further information can be found in separate data sheet and/or operating instructions for FlexTop 2212 or FlexTop 2222

TFR5

Room or outdoor temperature sensor

Dimensions and mounting

Wall mounting

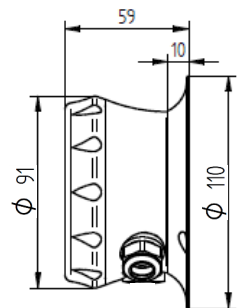

PCD for holes: Ø95 mm

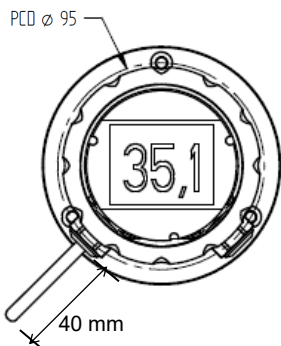

Can be delivered with cable between sensor and housing in free selectable length



Cable sensor

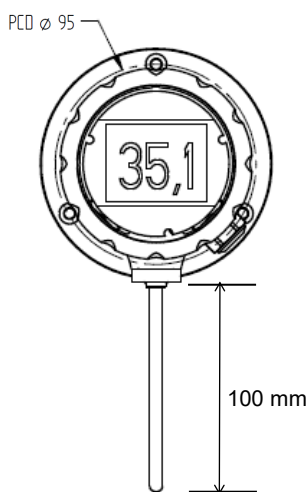

Fixed sensor

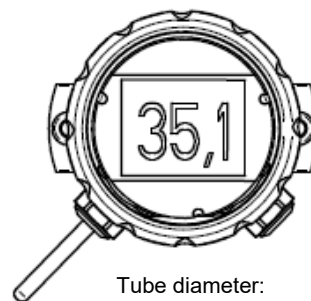
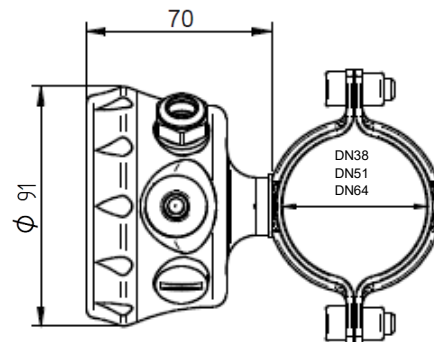

Tube diameter: Ø38 mm
Ø51 mm
Ø64 mm

Warning

Note: Check the maximum temperature for the cable used, if not Baumer sensor.
Cable diameter for M16 cable gland (black) 3...9 mm

Electrical connection

Ceramic terminal block

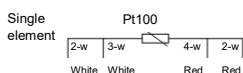
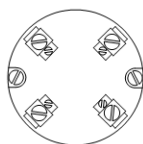

Temperature transmitter

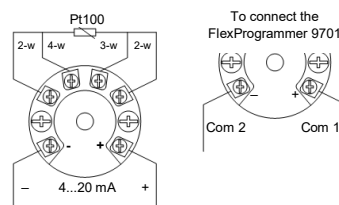

M12 plug

5-wire Pt100

- 1+2 Pt100
- 3+4 Pt100
- 5 N.C.

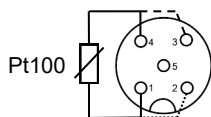

5-wire 4-20 mA

- 1 + supply, 4-20 mA
- 2 Common for relays
- 3 - supply, 4-20 mA
- 4 Relay 2
- 5 Relay 1

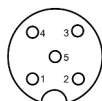

8-wire 4-20 mA

- 1 N.C.
- 2 + supply, 4-20 mA
- 3 Relay 2
- 4 Relay 2
- 5 Relay 1
- 6 Relay 1
- 7 - supply, 4-20 mA
- 8 N.C.

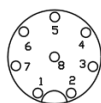

Cable gland

- 1 + 4...20 mA
 - 2 - 4...20 mA
 - 3 Relay 21
 - 4 Relay 22
 - 5 Relay 11
 - 6 Relay 12
- (3 + 5 can be connected as common)

To connect the FlexProgrammer 9701
COM 1 Red clip
COM 2 Black clip

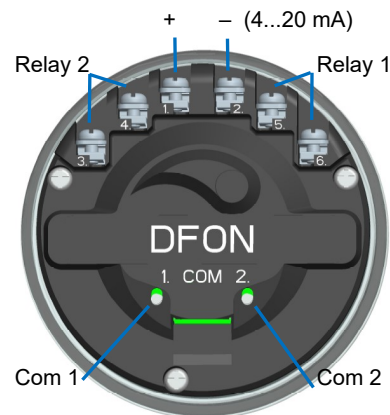

⚠ When upgrading the TFR5 without display with a DFON touch screen, remember to remove the O-ring from the sealing. Otherwise the sealing won't be tight.

TFR5

Room or outdoor temperature sensor

Hazardous area (ATEX/IECEX)

The CombiTemp™ TFR5 can be supplied for hazardous area. Either as a Simple Apparatus with RDT output or with built in transmitter with 4 ... 20 mA output.

A CombiTemp™ TFR5 with built in transmitter will have two possible ATEX/IECEX approvals, Ex ia (zone 0, 1 or 2) or Ex ec (zone 2).

⊕ II 1 G Ex ia IIC T6...T4

⊕ II 3 G Ex ec IIC T5...T4

The remaining Ex parameters depend on the type of transmitter and display selected for the product. See detailed data below.

The CombiTemp™ TFR5 with Ex ia must be installed in accordance with prevailing guidelines for zone 0 and zone 1 and a certified intrinsically safe zener barrier with the listed maximum values must be used. Electrical connection for the temperature transmitter as per below diagram.

CombiTemp™ TFR5 with Ex ec must be installed in accordance with prevailing guidelines for zone 2 without a barrier.

When using CombiTemp™ TFR5 as simple apparatus in zone 0 with group IIC explosive atmosphere the housing must be connected to ground.

When using CombiTemp™ TFR5 as simple apparatus a certified intrinsically safe barrier with the listed maximum values must be used.

If electrostatic dissipative film on display becomes damaged discontinue use in zone 0.

Electrical connection without display, Ex ia

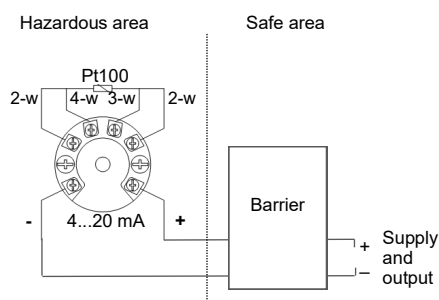

Suitable barrier: ZEX-ALL.B28RD100

Ex ia with FlexTop™ 2202 without display

Limit values	U_i :	28 VDC
	I_i :	0.1 A
	P_i :	0.7 W
	L_i :	10 μ H
	C_i :	10 nF
Temperature class	T1...T5:	-40 < Tamb < 85°C
	T6:	-40 < Tamb < 50°C

Ex ia with FlexTop™ 2212 / 2222 without display

Limit values	U_i :	30 VDC
	I_i :	0.095 A
	P_i :	0.75 W
	L_i :	24 μ H
	C_i :	11 nF
Temperature class	T4:	-20 < Tamb < 80°C
	T5:	-20 < Tamb < 71°C
	T6:	-20 < Tamb < 56°C

Ex ec with FlexTop™ 2202 / 2212 / 2222

Supply range	U_n :	30 V DC, max.
	I_n :	0.02 A
Temperature class	With display:	
	T4:	-20 < Tamb < 70°C
	T5:	-20 < Tamb < 60°C
	Without display:	
	T5:	-40 < Tamb < 80°C

Ex-data for Simple apparatus (no transmitter or display)

Approval	Simple apparatus Da / Ga (IEC 60079-11)	
Limit values	U_i :	15 VDC
	I_i :	0.05 A
	P_i :	0.025 W
	L_i :	0 μ H
	C_i :	0 nF
Temperature class	T1...T5:	-40 < Tamb < 85°C
	T6:	-40 < Tamb < 55°C
	T135°C:	-40 < Tamb < 85°C

TFR5

Room or outdoor temperature sensor

Ex ia, DFON relays

Limit values	U_i :	30 VDC
	I_i :	0.075A
	P_i :	0.75 W
	L_i :	10 μ H
	C_i :	10 nF
Temperature class	T4 :	-20 <Tamb <65°C
	T5:	-20 <Tamb <60°C

Ex ia with FlexTop™ 2202 and DFON display

Limit values	U_i :	30 VDC
	I_i :	0.1 A
	P_i :	0.7 W
	L_i :	20 μ H
	C_i :	25 nF
Temperature class	T4 :	-20 <Tamb <65°C
	T5:	-20 <Tamb <60°C

Electrical connection with DFON display, Ex ia

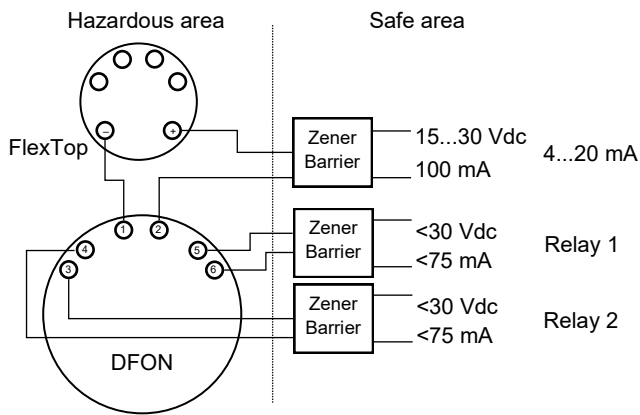

Ex ia with FlexTop™ 2212 / 2222 and DFON display

Limit values	U_i :	30 VDC
	I_i :	0.095A
	P_i :	0.75 W
	L_i :	34 μ H
	C_i :	26 nF
Temperature class	T4 :	-20 <Tamb <65°C
	T5:	-20 <Tamb <60°C

If the relays are enabled, each relay must be protected by a zener barrier. Use a barrier for each relay or a barrier with multiple channels. The two relays must have separate circuits.

Suitable barrier: ZEX-ALL.B30RS075

TFR5

Room or outdoor temperature sensor