

Accessories, Zubehör, Accessoires

Clamp ring, Klammer, bague de serrage



ZPX4-310 DN 38
ZPX4-610 DN 51
ZPX4-810 DN 76

Clamp gasket, Clamp Dichtring, Clamp Joint



ZPX3-7234 DN 38 EPDM (EHEDG)



ZPX3-7232 DN 38 EPDM
ZPX3-7332 DN 38 FKM
ZPX3-7262 DN 51 EPDM

Gasket, Dichtung, Joint (DIN 3869)



ZPX2-910	G1/4 DIN 3852 form E	NBR
ZPX2-920	G1/4 DIN 3852 form E	EPDM
ZPX2-930	G1/4 DIN 3852 form E	FKM
ZPX2-410	G1/2 DIN 3852 form E	NBR
ZPX2-420	G1/2 DIN 3852 form E	EPDM
ZPX2-430	G1/2 DIN 3852 form E	FKM
ZPX2-D10	G3/4 DIN 3852 form E	NBR
ZPX2-D20	G3/4 DIN 3852 form E	EPDM
ZPX2-D30	G3/4 DIN 3852 form E	FKM

Accessories, Zubehör, Accessoires

Union nut, Überwurfmutter, Écrou tournant



ZPX4-330	DN 38	SMS 1145
ZPX4-630	DN 51	SMS 1145
ZPX4-140	DN 25	DIN 11851
ZPX4-440	DN 40	DIN 11851 / DIN 11864-1
ZPX4-540	DN 50	DIN 11851 / DIN 11864-1
ZPX4-740	DN 65	DIN 11851

Gasket, Dichtung, Joint



ZPX3-8130	DN 38	SMS 1145	NBR
ZPX3-8160	DN 51	SMS 1145	NBR
ZPX3-9110	DN 25	DIN 11851	NBR
ZPX3-9140	DN 40	DIN 11851	NBR
ZPX3-9150	DN 50	DIN 11851	NBR
ZPX3-9170	DN 65	DIN 11851	NBR

O-ring, Joint torique



ZPX2-112	DN 38	3A DN 38	NBR
ZPX2-123	DN 38	3A DN 38	EPDM
ZPX2-132	DN 38	3A DN 38	FKM
ZPX2-223	DN 76	3A DN 76	EPDM
ZPX2-823		Varivent Type F	EPDM
ZPX2-323		Varivent Type N	EPDM
ZPX2-A22		DIN11864-1-A DN 40	EPDM
ZPX2-B22		DIN11864-1-A DN 40	EPDM
ZPX2-A32		DIN11864-1-A DN 50	FKM
ZPX2-B32		DIN11864-1-A DN 50	FKM

Blind plug, Blindstopfen, Bouchon

G1/8 hygienic/hygienerect/hygiénique



ZPX5-12

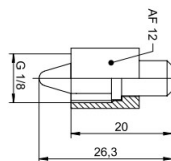

M12x1.5 hygienic/hygienerect/hygiénique



ZPX5-22

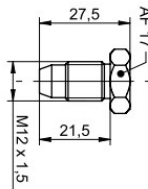

G1/2 A hygienic/hygienerect/hygiénique



ZPX5-32

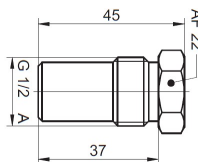

Blind plug, Blindstopfen, Bouchon

G1 A hygienic/hygienerect/hygiénique



ZPX5-62

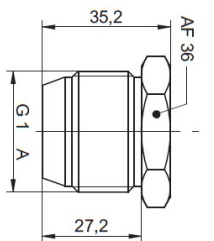

3A DN 38



ZPX5-82

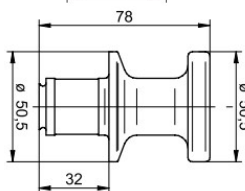

3A DN 76



ZPX5-92

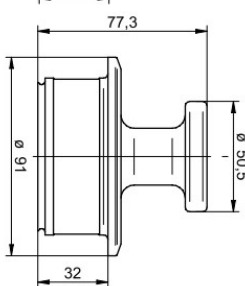

Instrument connection

M12x1.5

G1/2 A hygienic

G1 A hygienic

Accessories type

ZPH1-2...

ZPH1-3...

ZPH3-3...

ZPH1-3...

ZPH1-5...

ZPH3-5...



11152118 (12)

Baumer A/S

Runetoften 19 • 8210 Aarhus V • Denmark

Phone: +45 8931 7611 • Fax: +45 8931 7610

www.baumer.com • e-mail: sales.cc-ict@baumer.com

EN - Mounting instruction

When mounting a hygienic adapter the leakage indication ① must be placed at the lowest possible point.

Tighten the nipple according to the installation manual of the product. After installation check the leak tightness of the adapter. If the seal is leaking and the media appears in the inspection hole, the seal is to be changed immediately. Before reassembly, clean the hole and inside of the connection with detergent and sanitising liquid. Use a small brush. Verify that all of the inside area is completely clean. Reassemble and verify that the connection is tight.

In order to maintain compliance with EHEDG and 3-A Sanitary Standards for DIN 11851 these connections must be fitted with a special gasket from either SKS Komponenten System (SKS) B.V. or Asepto Star k-flex gasket from Kieselmann GmbH.

Maintenance of O-rings and gaskets on a 3-A marked unit

To ensure an optimal bacterial tight seal, the O-ring or gasket shall be renewed every time the instrument is removed. Otherwise, it is recommended to change the O-ring or gasket at 3 months interval. The interval may be extended if a test or historical evidence shows that the O-rings or gaskets can maintain their integrity under the specific conditions of use.

When removing or changing the O-rings or gaskets check the sealing surfaces for defects. If a defect is evident in the sealing area change the unit or contact Baumer A/S for assistance.

DE - Montageanleitung

Bei der Montage eines hygienischen Adapters muss die Leckanzeige ① am tiefsten Punkt platziert werden. Einschrauben des Nippels erfolgt gemäß der Bedienungsanleitung des Produkts.

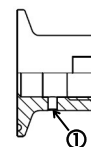
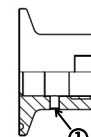

Nach der Installation ist die Dichtheit des Adapters zu prüfen. Bei einer Leckage, erkennbar am austretenden Medium an der Leckage Bohrung, muss die Dichtung umgehend ausgetauscht werden.

Vor dem Wiedereinbau reinigen Sie die Bohrung und das Innere des Prozessanschlusses mit einer Wasch- und Reinigungsflüssigkeit. Benutzen Sie dazu einen kleinen Pinsel. Überprüfen Sie, ob der ganze Innenraum vollständig sauber ist.

Stellen Sie nach dem Zusammenbau sicher, dass die Verbindung dicht ist.

Um die Voraussetzungen der EHEDG und 3-A Hygiene-standards für DIN11851 zu erfüllen muss entweder eine Dichtung von SKS Komponenten System (SKS) B.V. oder eine Asepto Star k-flex Dichtung von Kieselmann GmbH verwendet werden.

Wartung von O-Ringen und Dichtungen an einer mit 3-A gekennzeichneten Einheit

Um eine optimale bakterienrichte Abdichtung zu gewährleisten, muss der O-Ring oder die Dichtung jedes Mal erneuert werden, wenn das Instrument entfernt wird. Andernfalls wird empfohlen, den O-Ring oder die Dichtung alle 3 Monate zu wechseln. Das Intervall kann verlängert werden, wenn ein Test oder ein historischer Nachweis zeigt, dass die O-Ringe oder Dichtungen unter den spezifischen Verwendungsbedingungen ihre Unversehrtheit behalten können.

Überprüfen Sie beim Entfernen oder Wechseln der O-Ringe oder Dichtungen die Dichtflächen auf Defekte. Wenn im Dichtungsbereich ein Defekt erkennbar ist, tauschen Sie das Gerät aus oder wenden Sie sich an Baumer A/S.

FR - Instructions de montage

Lors du montage d'un adaptateur hygiénique, le trou de fuite ① doit être placé au point le plus bas possible. Serrez conformément au manuel d'installation du produit. Après installation, vérifiez l'étanchéité du manchon. Si le joint n'est pas étanche et que le média apparaît dans le trou d'indication de fuite, le joint doit être changé immédiatement.

Avant le remontage, nettoyez le trou et l'intérieur du raccord avec un détergent et un liquide de désinfection. Puis utiliser une petite brosse. Vérifiez que toute la zone à l'intérieur est complètement propre. Remonter et vérifier que la connexion est bien étanche.

Ces raccords doivent être munis d'un joint d'étanchéité spécial SKS Komponenten System (SKS) B.V. ou Asepto Star k-flex de Kieselmann GmbH afin de rester en conformité avec les normes sanitaires EHEDG et 3-A norme DIN 11851.

Maintenance des joints toriques et des joints sur une unité marquée 3A

Pour assurer une étanchéité optimale contre les bactéries, le joint torique ou le joint doit être renouvelé chaque fois que l'instrument est retiré. Autrement, il est recommandé de changer le joint torique ou le joint tous les 3 mois. L'intervalle peut être prolongé si un test ou des éléments de preuve historiques montrent que les joints toriques ou les joints d'étanchéité peuvent conserver leur intégrité dans les conditions spécifiques d'utilisation.

Lors du retrait ou du remplacement des joints toriques ou des joints, vérifiez l'absence de défauts sur les surfaces d'étanchéité. Si un défaut est visible dans la zone de soudure, changez l'unité ou contactez Baumer A/S pour obtenir de l'aide.

Gasket/O-ring, Dichtung/O-Ring, Joint/joint torique



Note that gaskets and O-rings for hygienic connections must apply to FDA, 3-A and/or EHEDG.

Dichtungen und O-Ringe für die hygienischen Anschlüsse müssen FDA, 3-A und/oder EHEDG konform sein.

Joints et joints toriques pour raccords hygiéniques doivent répondre à la FDA, 3-A et/ou EHEDG.

ISO 2852 Clamp

G1/2 A hygienic/hygienegerecht/hygiénique

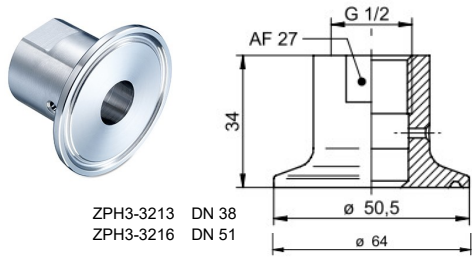

G1 A hygienic/hygienegerecht/hygiénique

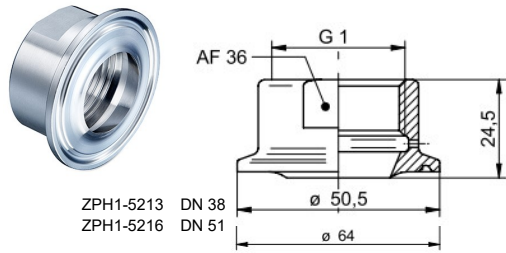

Varivent® type N

G1/2 A hygienic/hygienegerecht/hygiénique

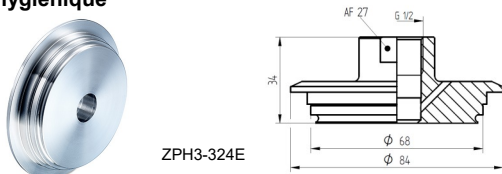

G1 A hygienic/hygienegerecht/hygiénique

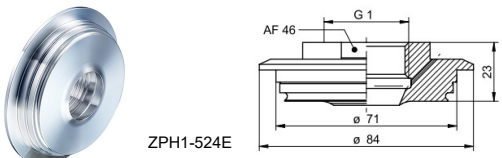

Varivent® type F

G1/2 A hygienic/hygienegerecht/hygiénique

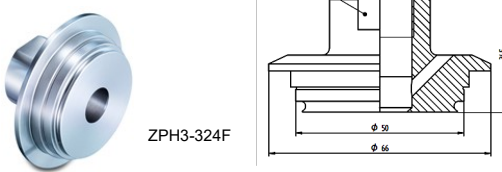

SMS 1145

G1/2 A hygienic/hygienegerecht/hygiénique

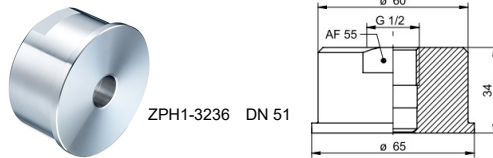

G1 A hygienic/hygienegerecht/hygiénique

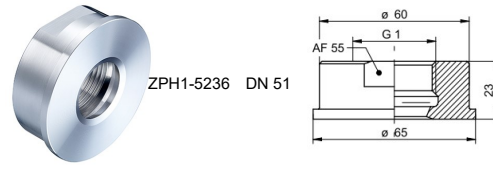
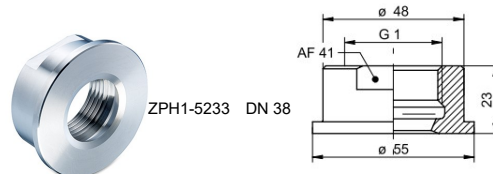

Vibrating fork, Schwinggabel, Adaptateur pour lames vibrantes

G1/2 A hygienic/hygienegerecht/hygiénique

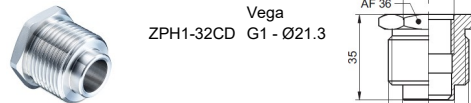
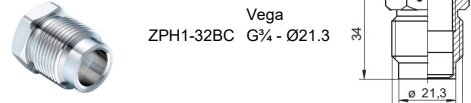
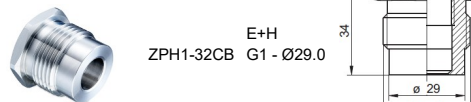
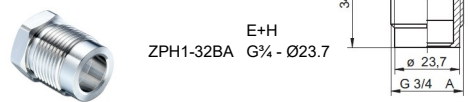

DIN 11851

G1/2 A hygienic/hygienegerecht/hygiénique

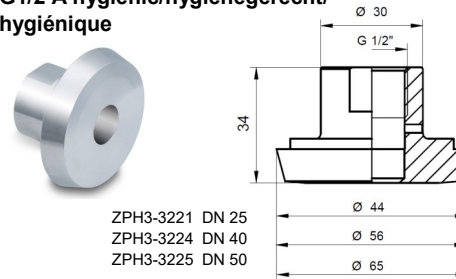

G1 A hygienic/hygienegerecht/hygiénique

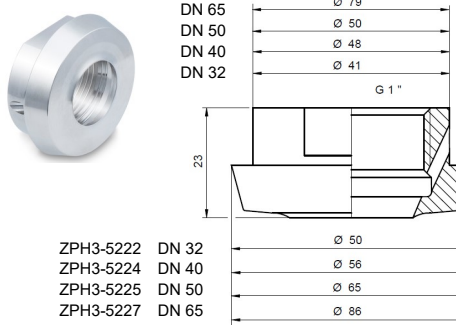

Special connections, Sonderanschlüsse, Raccords spéciaux

G1/2 A hygienic/hygienegerecht/hygiénique

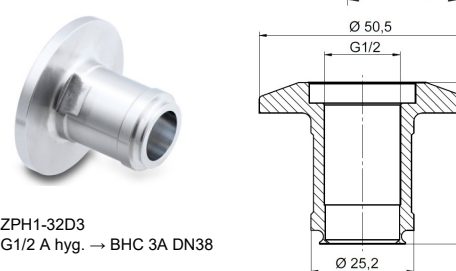
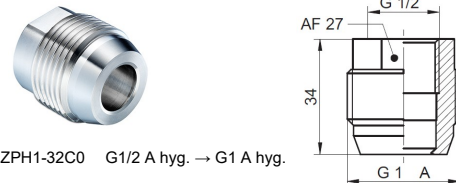
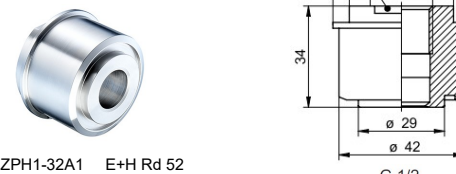

DIN 11864-1 form A

G1/2 A hygienic/hygienegerecht/hygiénique

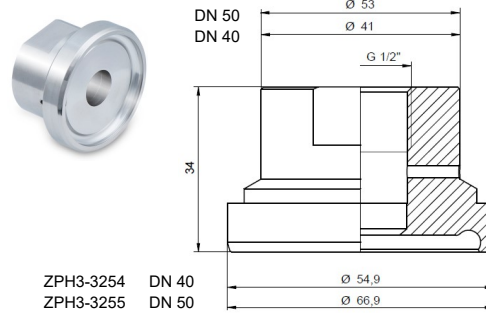

G1A hygienic/hygienegerecht/hygiénique

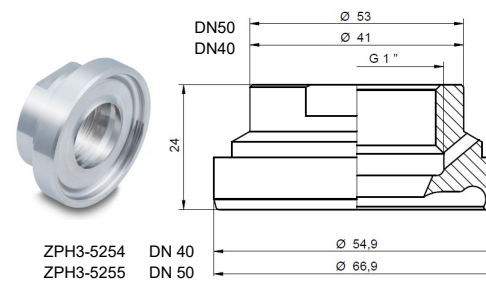

Industrial connection, Industrielle Anschlüsse, Raccords industriels

G1/2 A hygienic/hygienegerecht/hygiénique

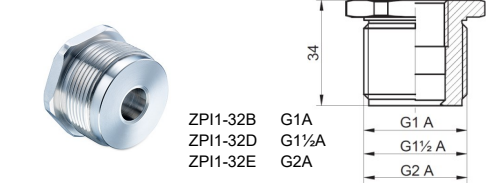

Special connections, Sonderanschlüsse, Raccord spéciaux

LBFS Cable hanger / Kabelaufhängung / porte-cable

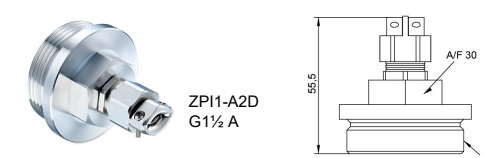

LBFS Sliding connection / Schiebanschluss / Raccord coulissant

