

VeriSens® – Measuring with VeriSens®

AN201407/v0.2/2023-08-21

Description

In this document we will give answers to questions that are asked very often regarding measurement possibilities and limitations.

Products

VeriSens® Vision Sensors

Preparation

-

Contents

1	Measuring with VeriSens® FAQs	2
1.1	Is it possible to measure objects with VeriSens®?	2
1.2	How can I decide whether VeriSens® meets my measurement requirements?	2
1.3	What influence does the illumination have on the measurement results?	3
1.4	What influence does the lens have on the measurement result?	4
1.5	How accurate can I measure using VeriSens®?	6
1.6	Which resolutions do I need for which measurement accuracy?	6
1.7	Can VeriSens® also output the results in mm?	7
1.8	Can VeriSens® determine all measures with sub pixel accuracy?	8
1.9	What does sub pixel accuracy mean?	8
2	Support	9
3	Disclaimer	9

1 Measuring with VeriSens® FAQs

1.1 Is it possible to measure objects with VeriSens®?

Measuring is a task to generate a quantitative statement about a measurand by comparing it with a unit (see DIN 1319-1:1995). Using VeriSens®, this comparison is based on “counting” pixels. As soon as a certain length can be assigned to one pixel by calibration, the measurement of lengths (and by that also angles) is possible.

You have to know about limits and limitations. A VeriSens® is not a calibrated measurement device – as a compact image processing system it becomes part of the customer's application. The attainable results decisively depend on the components used (lens, illumination, resolution of VeriSens®) and on their setup (positioning of VeriSens® regarding to illumination and object, its stability and precision). Whether VeriSens® is suitable for a certain application has to be tested individually. Read more about this topic in the following chapters.

1.2 How can I decide whether VeriSens® meets my measurement requirements?

Depending on industry and customer the requirements on a measuring instrument can vary. The evaluation has to be in accordance with the specific requirements.

Level 1: Spec/part drawing states tolerance of 20.00 +/- 0.3 mm

Firstly the VeriSens® and field of view (FOV) have to be chosen so that one pixel resembles maximum 5% of the entire tolerance. In our case this would be 0.03 mm per pixel ($(0.3 - (-0.3)) \text{ mm} * 5\% = 0.03\text{mm}$).

Secondly it has to be made sure that the length has to be measured with a calibration standard. This calibration standard has to have maximum 5% tolerance itself.

The customer has to check the calibration regularly (according to his rules for measuring equipment monitoring).

Possible, if both conditions are fulfilled.

Does Baumer provide or offer calibration standards? - No, because they will have to be suitable for the measurement parameter and have to be manufactured accordingly in detail. Normally, customers have their own calibration standards for the measuring equipment monitoring.

Level 2: Measurement Systems Analysis (MSA), “Procedure 1”. Specification by process capacity index c_g and c_{gk} :

If a proof of measurement equipment ability is needed on behalf of the customer, this will be done following the guidelines of procedure 1. For that, a test object of a known magnitude (verification officer, calibration standard) is measured 50 times. The deviation of the mean from the standard gives the accuracy. The repeatability is given by the standard deviation.

Both values are part of the calculation of the measuring equipment capability indexes c_g and c_{gk} .

The system is capable, if the standards (typical 1.33 to 1.67) are fulfilled.

Without telecentric optics and back light normally this is not manageable with VeriSens®. Such applications can only be solved by the customer himself in his machine system and with responsibility at his side.

Level 3: Measurement equipment capability check, “Procedure 2” (and “3”). Specification by R&R*: Here a statistic check of several inspection parts has to be done throughout the whole range of variation of the measurement parameter.

*) repeatability and reproducibility

VeriSens® is not appropriate to this level. The customer has to implement this in his machine system in his own responsibility.

1.3 What influence does the illumination have on the measurement results?

The applied illumination has an immense influence on the measurement results. Different illuminations can lead to very different results and measurement accuracy. The light interacts with the material of the object. Reflections and absorption become visible in the image. Depending on the positioning of the illumination, material properties and form of the edges this can lead to extremely distinct measurement results.

For this reason a **back light** is used for measurement applications whenever it is possible. For some applications (e.g. circuit board inspection) also the use of coaxial light can make sense. By using a back lighting, you place the object between the camera and a homogenous illumination. Thereby a silhouette of the test object is created. This setup mostly leads to a result that is independent from material and form.

The following images show an object illuminated by backlight and front lighting (illumination from above). In the combined image it is clearly visible that the edges are in different positions within the image.

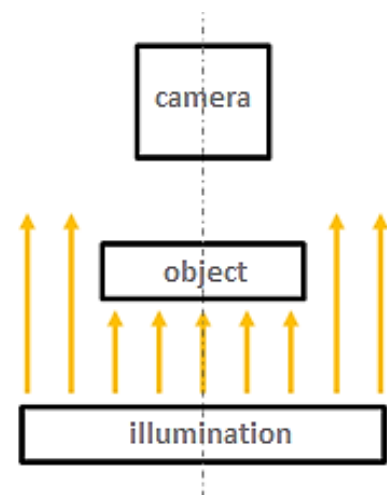

Object to be checked

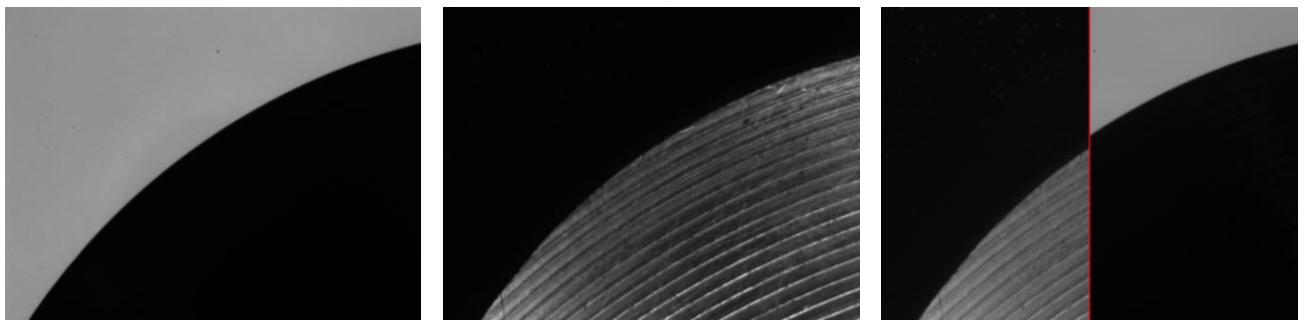

Back lighting (object between illumination and camera)

Front lighting (object illuminated from above)

Comparison front lighting /back lighting

The following sketch shows you, why this is the case:

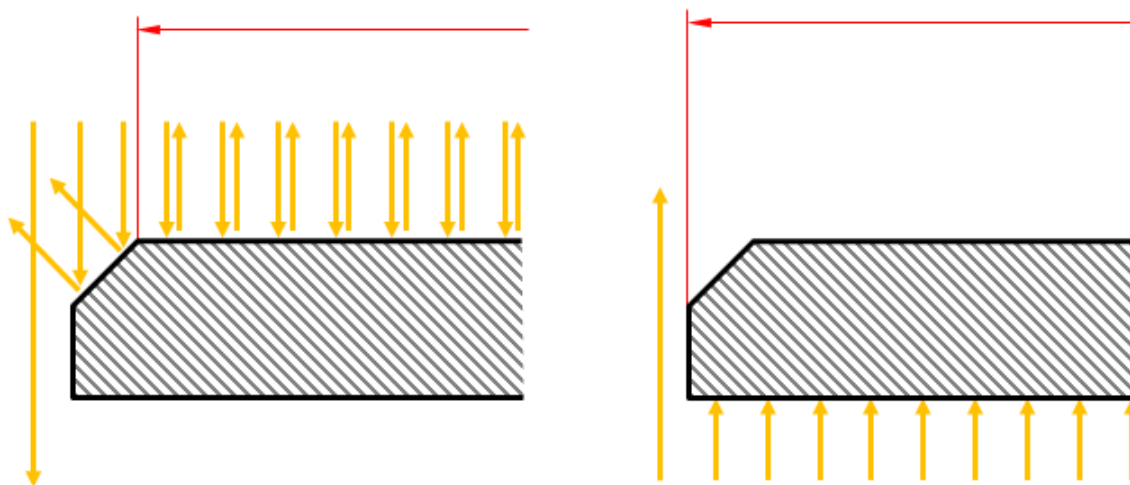

Front lighting

Back lighting

The Front lighting leads to a smaller width in the image, because at the chamfer the light is reflected away from the lens. On the opposite with the back lighting, the areas that are placed between illumination and camera independent from angle and surface occur to be black. So a correct result can be determined.

1.4 What influence does the lens have on the measurement result?

The choice of the right lens has, as well as the illumination, an important influence on the measurement result. The camera does not capture the object itself, but the image that is projected on the image sensor by the optics. The dimensioning and quality of this optics ultimately decides how accurate an object can be inspected.

Even perfect lenses create point images. This is related to the applied aperture. The point image can be rated by multiplying the aperture * 1.3 micrometer. In case the size of a point in the image is larger than the pixel (absolute value), the effective number of pixels will be reduced and the resolution (see level 1) decreases accordingly.

Each lens produces certain faults that have a negative influence on the image and measurement quality. The most important faults are:

- Lens distortion
- Perspective faults

Beside that some other effects occur that may have a negative influence on the measuring result, such as missing depth of sharpness, missing resolution capacity of the optics, chromatic aberration, vignetting, coma, astigmatism, flare light ...

Lens distortion

The lens distortion is an image defect that leads to a geometrical distortion of the object, increasing with growing distance from the image center. Typically this effect is more prominent if wide angle lenses (meaning smaller focal distances) are applied. Accordingly lenses with a focal distance as high as possible or, even better, a telecentric lens (more in the following paragraph) should be used.

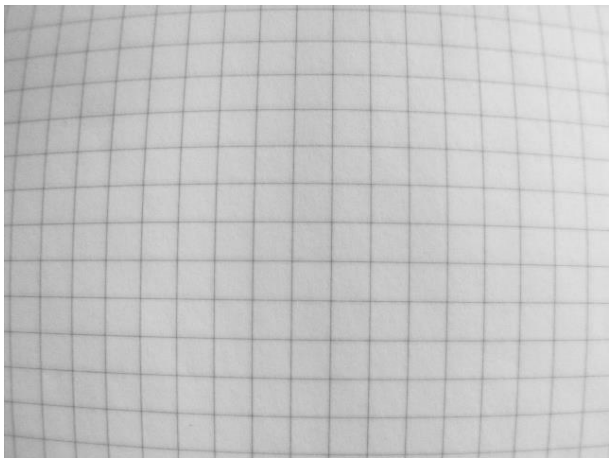

3,5mm lens

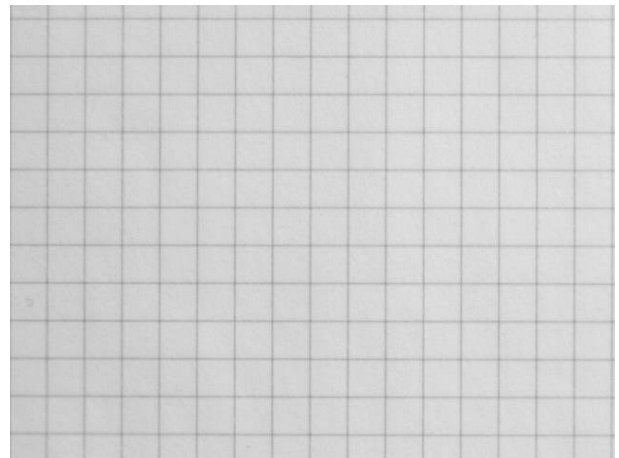

16mm lens

Perspective faults

There are two kinds of lenses:

- **Endocentric lenses** ("common lenses") - used for conventional applications. Effect: the farther away an object is from the camera, the smaller it appears to be.
- **Telecentric lenses** - lenses for highly accurate measuring applications. Effect: the size of an object stays the same within a defined area (telecentric area).

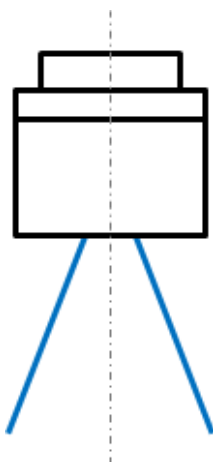

Endocentric lens

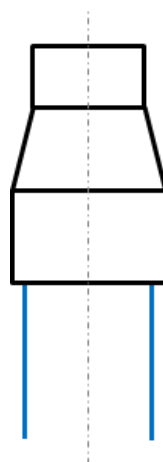

Telecentric lens

In case of common endocentric lenses are used, perspective faults occur. Objects that are farther away from the camera seem to be smaller. Objects near to the camera seem to be bigger. This also holds for parts that

are not completely flat. Measurements in different heights lead to different results. Similar, slight variations in height of the entire part cause measurement errors. The fault is the more significant, the smaller the focal distance of the lens is. The following images display a ruler that was placed in a 45° angle. They were taken with different lenses.

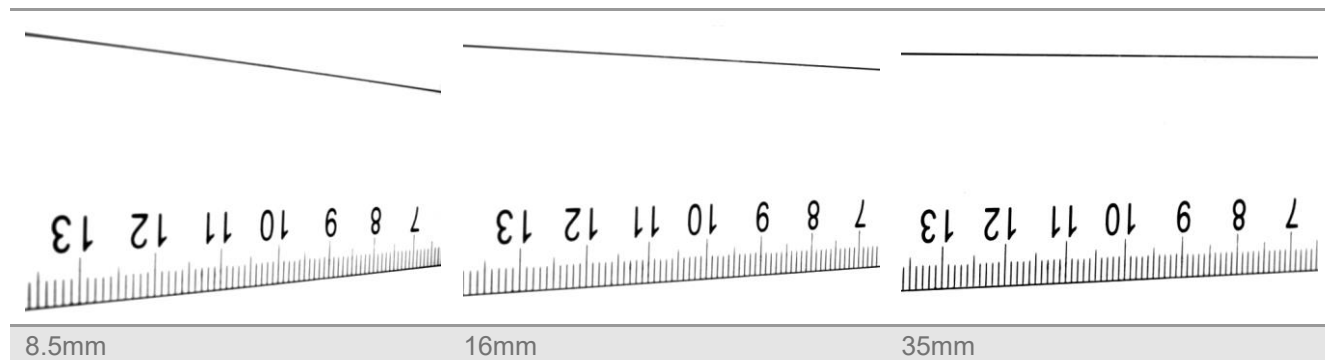

The fault that results from the high variation is underestimated.

Example: A VeriSens® XC with 1.2MP resolution (1/3" sensor) with a 16mm lens is positioned 200mm away from the object. With the given lens and distance, the field of view is 55mm wide. The lens has an aperture angle of 17°. A variation of the object distance of $\pm 0.5\text{mm}$ leads to a deviation of the object width in the image of no fewer than $\pm 0,15\text{mm}$.

For this reason, telecentric lenses are used for measurement applications with stringent requirements. Here the variation of the object width in the image is nearly 0.

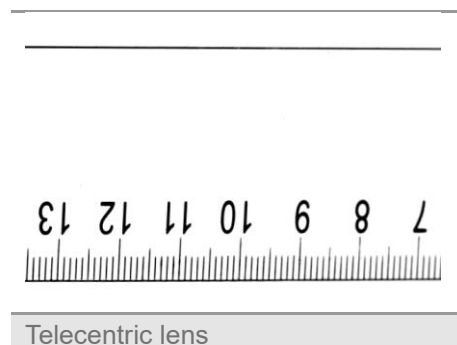

1.5 How accurate can I measure using VeriSens®?

This question cannot be answered generally, because numerous factors have an enormous effect on the measurement accuracy (also see: "What influence does the illumination have on the measurement result?" and "What influence does the lens have on the measurement result?"). Their influence can barely be calculated without having knowledge about applied optics and selected illuminations. The entire system/setup has to be tested in real-life conditions to reach a definite statement.

1.6 Which resolutions do I need for which measurement accuracy?

There is no general answer to this question. Especially for threshold it has to be dealt with individually. As a general rule, the resolution should at least be 20 times higher than the required tolerance.

Example:

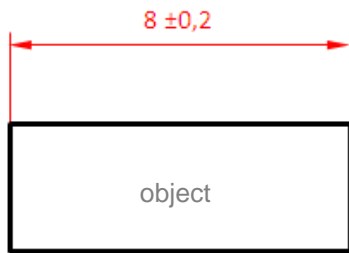

The width of the object shown above shall be checked. The overall tolerance shall be 0.4mm (upper minus lower tolerance). So the resolution should be at least $0.4\text{mm} / 20 = 0.02\text{mm}$ per pixel. In order to balance position variations, an image field of 12mm is chosen. If a *VeriSens*[®] XC with VGA resolution is used, a resolution of $12\text{mm} / 640\text{px} = 0.0187\text{mm}/\text{px}$ results. A *VeriSens*[®] with VGA resolution would be generally sufficient.

1.7 Can *VeriSens*[®] also output the results in mm?

Yes, the function is called „coordinate conversion“ (Adjust image > Coordinates). This feature converts the internal image coordinates (in pixels) to a user defined coordinate system. For that it is necessary to provide the real coordinates for some support points within the image related to a world coordinate system.

Example:

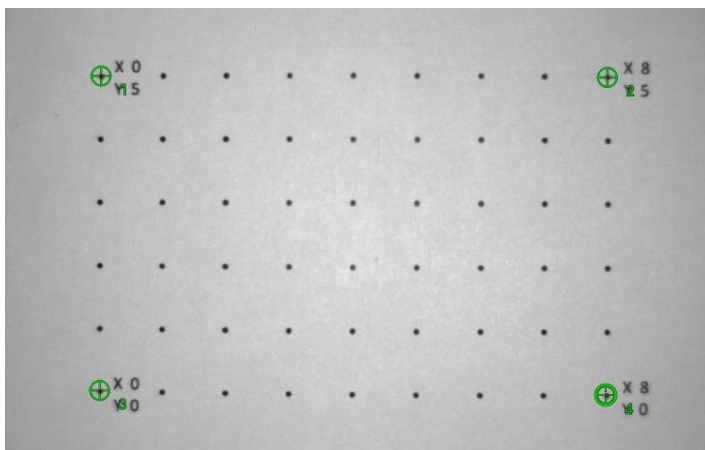
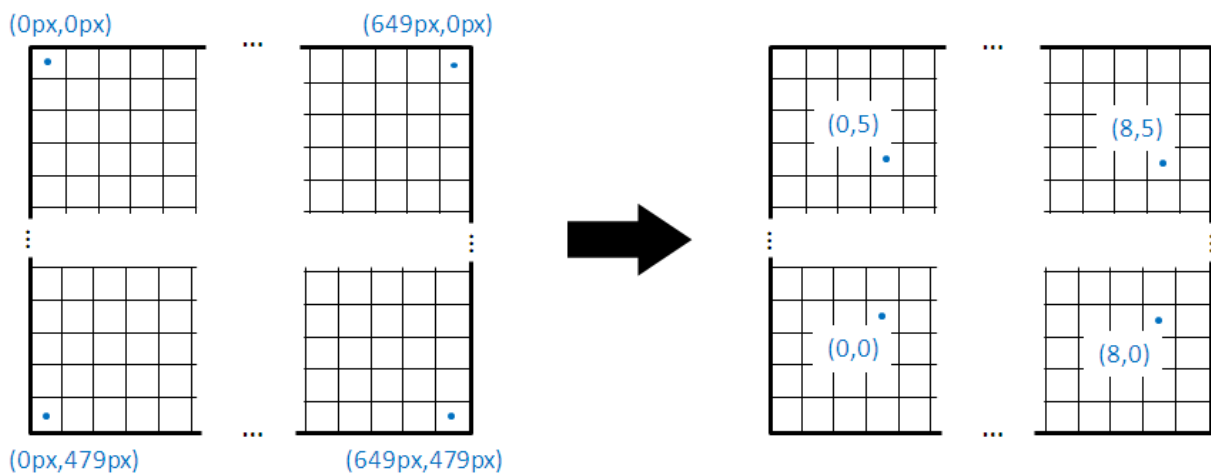

Example (included in the sample images of the AppSuite installation package)

1.8 Can VeriSens® determine all measures with sub pixel accuracy?

Yes, the VeriSens® calculates contour points with $\frac{1}{4}$ pixel accuracy. All geometry features are based on contours. If you want to see the results with sub pixel accuracy, the coordinate conversion has to be activated.

1.9 What does sub pixel accuracy mean?

Sub pixel accurate determination of edges means that the edges are found more accurate than 1 pixel. The edge is, in a way, found between 2 pixels. By that, the resolution can be raised “virtually”.

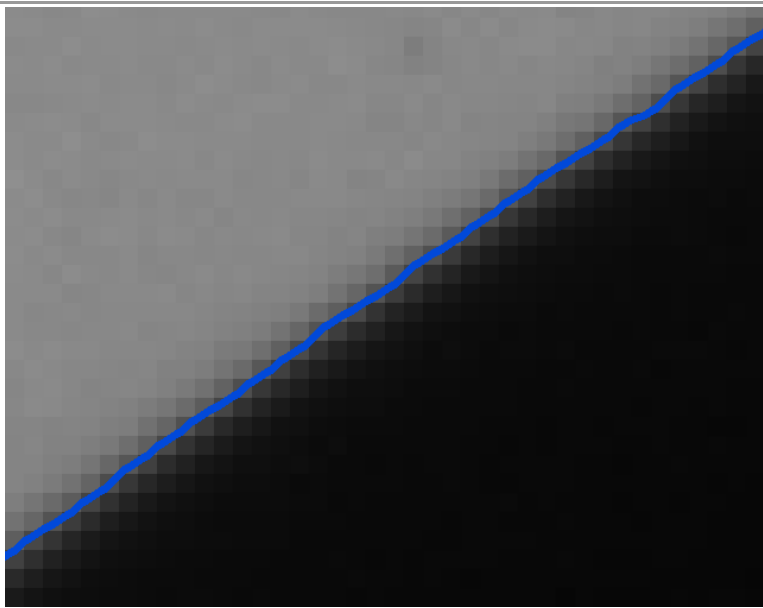

Sub pixel accurate determination of an edge. An edge does not always go through the center of a pixel. It is found with higher precision.

2 Support

In the case of any questions or for troubleshooting please contact our support team.

Worldwide

Baumer Optronic GmbH

Badstrasse 30 · DE-01454 Radeberg

Phone +49 3528 4386 845

support.verisens@baumer.com

3 Disclaimer

All product and company names mentioned are trademarks or registered trademarks of their respective owners.

All rights reserved. Reproduction of this document in whole or in part is only permitted with previous written consent from Baumer Optronic GmbH.

Revisions in the course of technical progress and possible errors reserved.

Baumer Group

The Baumer Group is an international leading manufacturer and developer of sensors, encoders, measuring instruments and components for automated image-processing. Baumer combines innovative technology and customer-oriented service into intelligent solutions for factory and process automation and offers a uniquely wide range of related products and technologies. With around 2,300 employees and 38 subsidiaries and in 19 countries, the family-owned company is always close to the customer. Industrial clients in many sectors gain vital advantages and measurable added value from the worldwide consistency of Baumer's high quality standards and its considerable innovative potential. For further information, visit www.baumer.com on the internet.

**Baumer Optronic GmbH**

Badstrasse 30 · DE-01454 Radeberg
Phone +49 3528 4386 0 · Fax +49 3528 4386 86
sales.cc-vt@baumer.com · www.baumer.com